

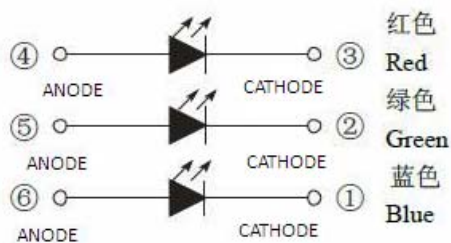

PRODUCT SPECIFICATION

SLM-3535RGB-002

Outline Dimension

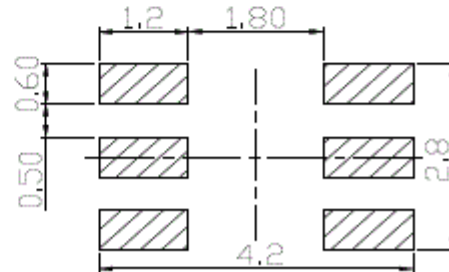
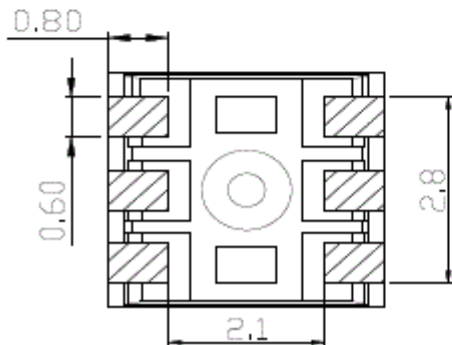
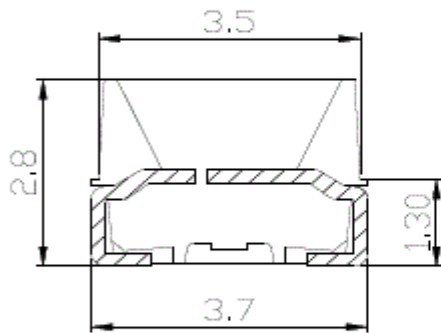
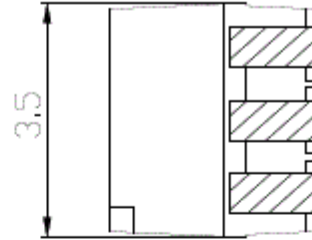
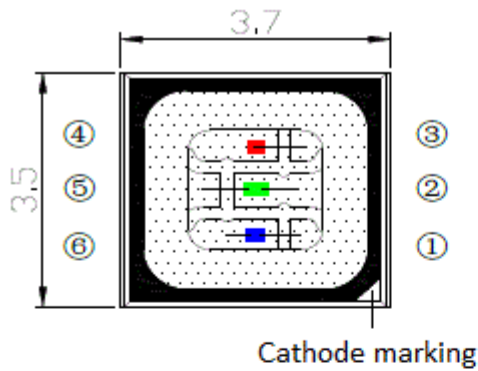

极性 Polarity

推荐焊盘
Recommended Soldering Pad

Note:
All dimensions in mm.
Tolerances: XX ±0.1 mm
 XXX ±0.05mm

Absolute maximum ratings at Ta=25°C

Parameter	Symbol	Rating	Unit
Power Dissipation	R	60	mW
	G	90	
	B	90	
Forward Current	IF	25	mA
Peak Forward Current *1	IFP	100	mA
Reverse Voltage	VR	5	V
Electrostatic Discharge	ESD	2000	V
Operating Temperature	Topr	-30~+85	°C
Storage Temperature	Tstg	-40 ~+100	°C

* Pulse width≤0.1msec Duty Ratio ≤1/10

Electro-optical characteristics at Ta=25°C

Parameter	Symbol	Min	Typ	Max	Unit	Condition
Forward Voltage	R	1.8	-	2.6	V	IF=20mA
	G	2.8	3.2	3.6		
	B	2.8	3.2	3.6		
Luminous Intensity	R	500	850	1450	mcd	
	G	1100	2350	3000		
	B	260	540	850		
Dominant Wavelength	R	615	620	630	nm	
	G	515	520	535		
	B	465	470	480		
Spectrum Radiation Bandwidth	R	-	20	-	nm	
	G	-	35	-		
	B	-	30	-		
View Angle	2θ _{1/2}	-	110	-	deg	-
Reverse Current	IR	-	-	10	μA	VR=5V

Bin Grouping:

Luminous Intensity

Blue (mcd)			Green (mcd)			Red (mcd)		
Rank	Min.	Max.	Rank	Min.	Max.	Rank	Min.	Max.
B1	260	380	G1	1100	1800	R1	500	650
B2	380	495	G2	1800	2350	R2	650	850
B3	495	650	G3	2350	3000	R3	850	1100
B4	650	850				R4	1100	1450

Wavelength

Rank	Blue (nm)		Green (nm)		Red (nm)	
	Min.	Max.	Min.	Max.	Min.	Max.
Full	465	480	515	535	615	630
W	465	470	515	520	615	620
X	470	475	520	525	620	625
Y	475	480	525	530	625	630
Z			530	535		

Forward Voltage

Rank	Blue (V)		Green (V)		Red (V)	
	Min.	Max.	Min.	Max.	Min.	Max.
V1	2.8	3.6	2.8	3.6	1.8	2.6

Typical Characteristics Curves

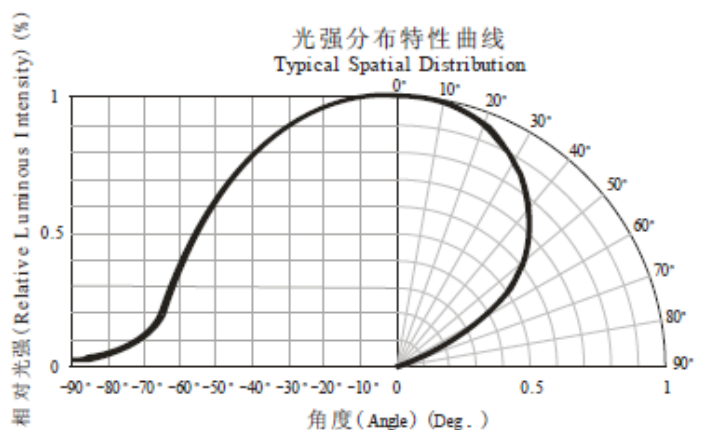
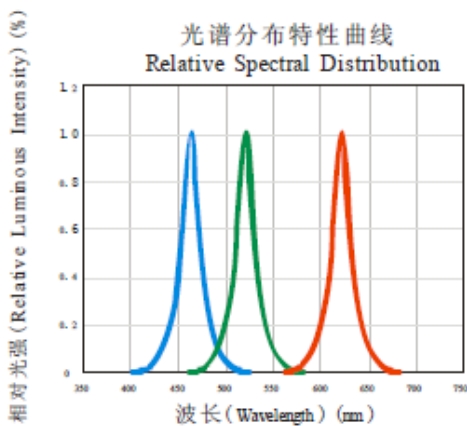
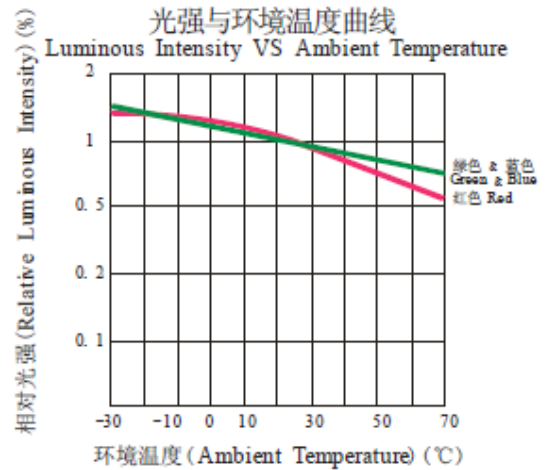
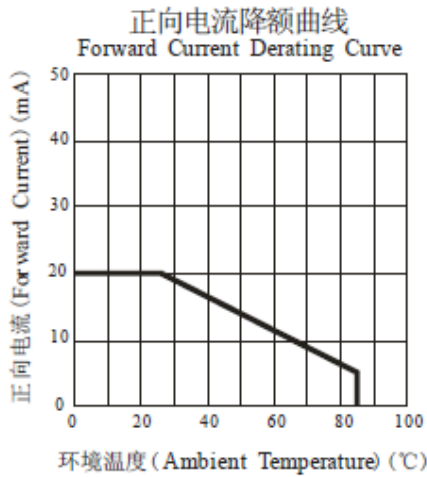
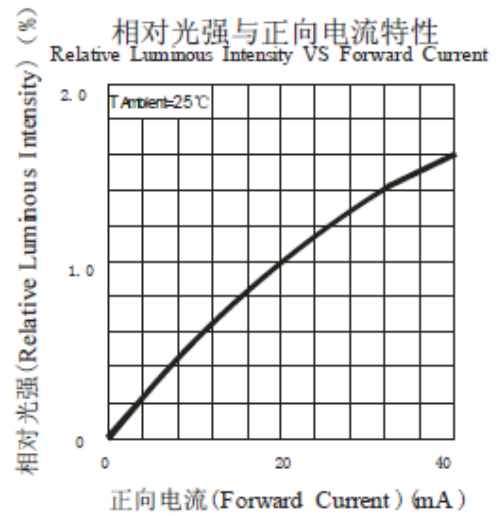
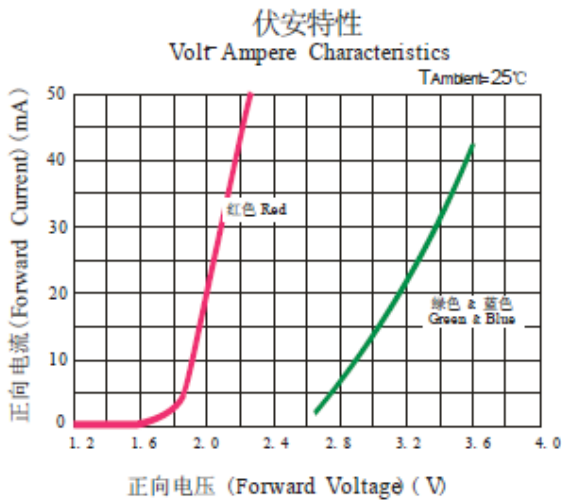

Guideline for Soldering

1. Hand Soldering

A soldering iron of less than 20W is recommended to be used in Hand Soldering. Please keep the temperature of the soldering iron under 300°C while soldering. Each terminal of the LED is to go for less than 3 second and for one time only.

Be careful because the damage of the product is often started at the time of the hand soldering.

2. Reflow Soldering: Use the conditions shown in the under figure of Pb-Free Reflow Soldering.

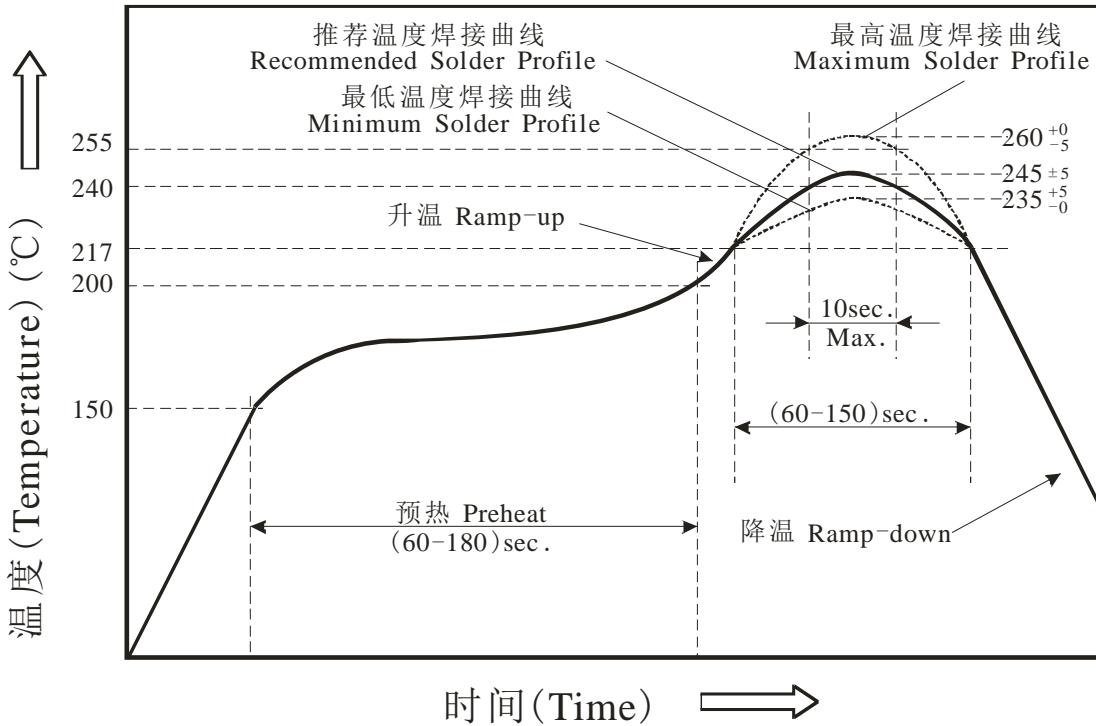

Reflow soldering should not be done more than two times.

Stress on the LEDs should be avoided during heating in soldering process.

After soldering, do not deal with the product before its temperature drop down to room temperature.

3. Cleaning

It is recommended that alcohol be used as a solvent for cleaning after soldering. Cleaning is to go under 30°C for 3 minutes or 50°C for 30 seconds. When using other solvents, it should be confirmed beforehand whether the solvents will dissolve the package and the resin or not.

Ultrasonic cleaning is also an effective way for cleaning. But the influence of Ultrasonic cleaning on LED depends on factors such as ultrasonic power. Generally, the ultrasonic power should not be higher than 300W. Before cleaning, a pre-test should be done to confirm whether any damage to LEDs will occur.

*Note: This general guideline may not apply to all PCE designs and configurations of all soldering equipment. The techniques in practice is influenced by many factors, it should be specialized base on the PCB designs and configurations of the soldering equipment.

**Packaging
Carrier Tape**

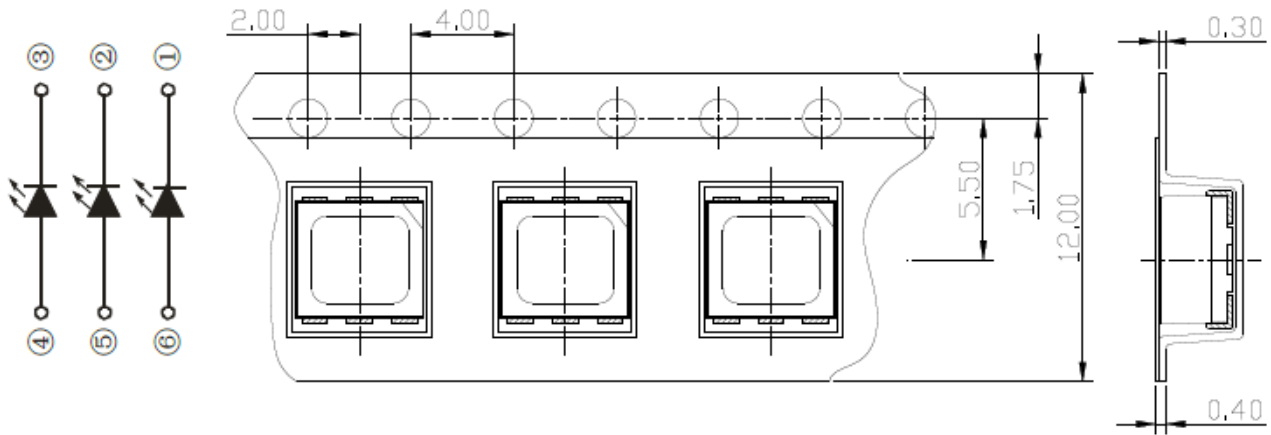

All dimensions in mm, tolerances unless mentioned is ± 0.1 mm.

Details of Carrier Tape

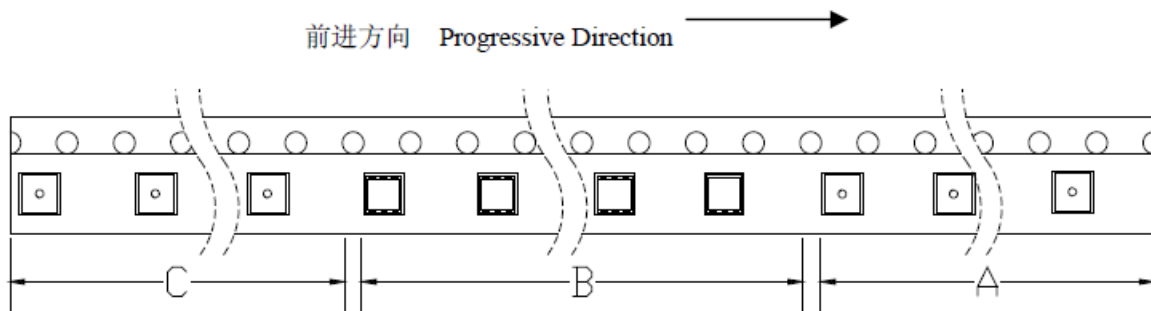

A: 引导, 空带, 500mm; B: 编载产品 4500 只; C: 尾部, 空带, 100mm
A: Leader, Empty, 500mm; B: 4500 Lamps Loaded; C: Trailer, Empty, 100mm.

Moisture Proof and Anti-Electrostatic Foil Bag

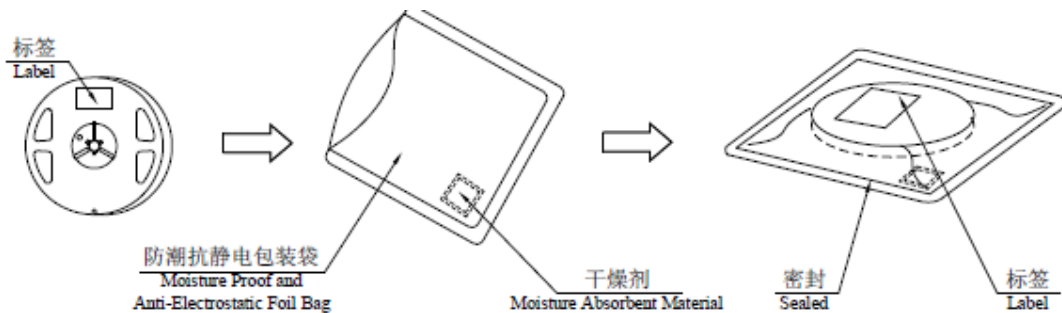

Precautions

1. Storage

Moisture proof and anti-electrostatic package with moisture absorbent material is used, to keep moisture to a minimum.

Before opening the package, the product should be kept at 30°C or less and humidity less than 60% RH, and be used within a year.

After opening the package, the product should be stored at 30°C or less and humidity less than 10%RH, and be soldered within 168 hours (7 days). It is recommended that the product be operated at the workshop condition of 30°C or less and humidity less than 60%RH.

If the moisture absorbent material has fade away or the LEDs have exceeded the storage time, baking treatment should be performed based on the following condition: (60±5)°C for 24 hours.

2. Static Electricity

Static electricity or surge voltage damages the LEDs. Damaged LEDs will show some unusual characteristics such as the forward voltage becomes lower, or the LEDs do not light at the low current., even not light. All devices, equipment and machinery must be properly grounded. At the same time, it is recommended that wrist bands or anti-electrostatic gloves, anti-electrostatic containers be used when dealing with the LEDs

Revision History

Page	Subjects	Date of Modification
	New Format	31-Jul-2013
3	Adjust Green Chip Luminous Intensity	
4	Add Bin Grouping	05-Dec-2013
3	Added ESD Information	31-Jul-2014
7	Correction - Packing drawing 2,500pcs to 3,000pcs Reel	05-Nov-2014
7	Updated – Packing drawing From 3,000pcs adjust to 4,500pcs per Reel	25-Nov-2016